

Description

BP2364XN is a high precision non-isolated APFC buck LED driver, specially designed for universal mains with constant current control. BP2364XN **operates in Critical Conduction Mode** to reduce the switching loss and optimize the EMI.

BP2364XN remove the VCC capacitor, COMP capacitor and R_{CS} resistor to simplify the external BOM. And it utilizes specific current detection, with few external components, it achieves high precision output current, excellent line regulation and load regulation.

BP2364XN offers full protection functions to improve the system reliability, including LED load short protection. The system reliability is further improved by the thermal regulation function. The output current is reduced when the driver is in condition of over temperature.

Features

- Active-PFC for High PF and Low THD
- No VCC and COMP capacitor
- Critical Conduction Mode Operation
- LED Short Protection
- LED Open Protection (OVP resistor ADJ)
- Enable function is compatible with switch color and sensor light
- Cycle by Cycle Current Limit
- Thermal Regulation Function
- Available in ASOP8 Package

Applications

- LED Bulb
- LED Tube
- Other LED Light

Typical Application

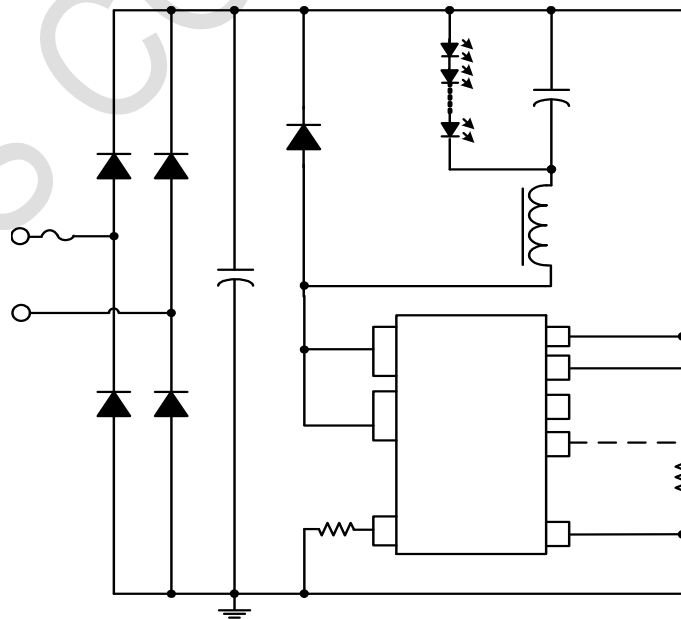
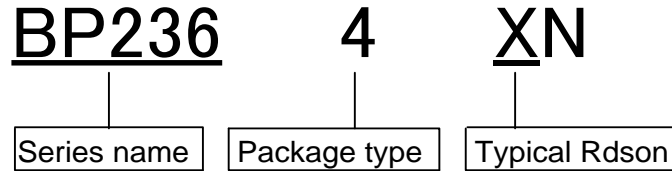

Figure 1. Circuit for typical application of BP2364XN

Naming rules



Ordering Information

Part Number	Package	Packing Method	Marking
BP2364XN	ASOP8	Tape 5,000 pcs/Reel	BP2364 XXXXXYN ZZZZWWX

Pin Configuration and Marking Information

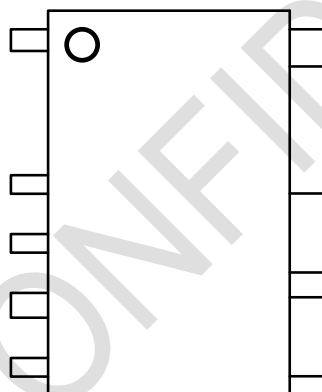

XXXX: Lot Code
ZZZZ: Sign
WW: Week

Figure 2. Pin configuration

Pin Definition

Pin No.	Name	Description
1	GND	Ground.
2	ROVP	OVP set pin.
3	NC	No connection
4	HV	High-voltage MOSFET gate drive pin.
5	VBUS	Rectifier bridge output positive pole
6,7	DRAIN	Internal HV Power MOSFET Drain.
8	CS	Current Sense Pin. Connect a sense resistor between this pin and GND pin.

Disclaimer

The information provided in this datasheet is believed to be accurate and reliable. However, Bright Power Semiconductor (BPS) reserves the right to make changes at any time without prior notice.

No license, to any intellectual property right owned by BPS or any other third party, is granted under this document. BPS provides information in this datasheet “AS IS” and with all faults, and makes no warranty, express or implied, including but not limited to, the accuracy of the information provided in this datasheet, merchantability, fitness of a specific purpose, or non-infringement of intellectual property rights of BPS or any other third party. BPS disclaims any and all liabilities arising out of this datasheet or use of this datasheet, including without limitation consequential or incidental damages.

BPS CONFIDENTIAL